

Floating Pump & Platform Assemblies

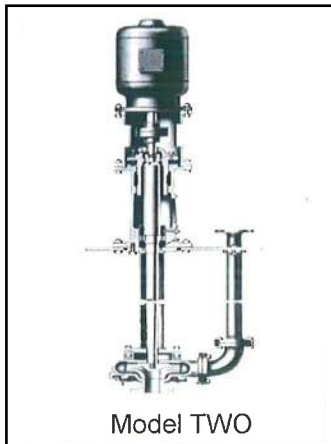

Model TWO

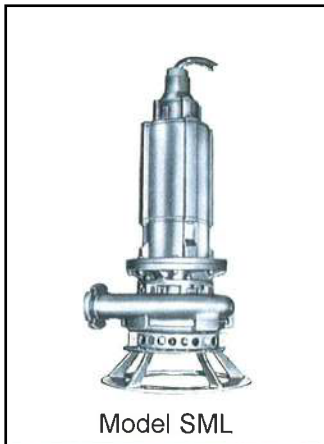

Model SML

Three Nagle Model TWO belt driven pumps and controls mounted on linked floating platforms have provided cooling water to an Eastern power plant since 1976



Single Model SML submersible pump and pontoon assembly ready for shipment. This design is very stable since the pump is mostly below the water line.

Single pump unit used for drainage transfer in a phosphate mine. This arrangement allows the pump to be tilted up for inspection and cleanout. The lifting bale enables easy pit transfers.



Applications:

- ◆ Cooling water return
- ◆ Waste pond discharge
- ◆ Drainage disposal
- ◆ Sumps with large level variations
- ◆ River water supply

Key Pump Considerations:

- ◆ Very high reliability is desirable due to limited accessibility to the equipment for maintenance
- ◆ Light weight and compact size is desirable due to lifting and handling limitations

Model TWO Features:

- ◆ Vertical cantilever shaft slurry pump design
- ◆ No seals, submerged bearings or other rubbing parts in contact with the pumpage results in the best possible pump life and reliability
- ◆ Belt driven or direct connected

Model SML Features:

- ◆ Submersible slurry pump design
- ◆ Lighter weight and lower center of gravity on platform allows smaller platform dimensions and greater stability
- ◆ Less costly and easier to handle for maintenance

Flow and Pressure:

- ◆ Flows to 6000 GPM
- ◆ Pressures to 150 psi

Pump Material Options:

- ◆ Cast Iron and Ductile Iron
- ◆ Abrasion resistant 28% Chromium Iron
- ◆ All corrosion resistant alloys

Floating Platform Options:

- ◆ Design of the floating platform and pumping machinery are integrated to assure proper stability, durability and performance
- ◆ Platform structures can be constructed of steel, aluminum or corrosion resistant materials
- ◆ Heavy duty marine pontoons are employed in a variety of designs and materials
- ◆ Access walkways, pipe supports, mooring and control equipment are also available

Nagle Pumps manufactures vertical cantilever, vertical submerged bearing, horizontal and submersible pumps for abrasive, corrosive, elevated temperature and hazardous fluid handling applications. See our Website for the representative in your area or contact Nagle Pumps directly.



Nagle Pumps, Inc.

3565 Dixie Hwy, Dry Ridge, KY 41035

Phone: 859.428.5416

www.NaglePumps.com

Sales@NaglePumps.com