

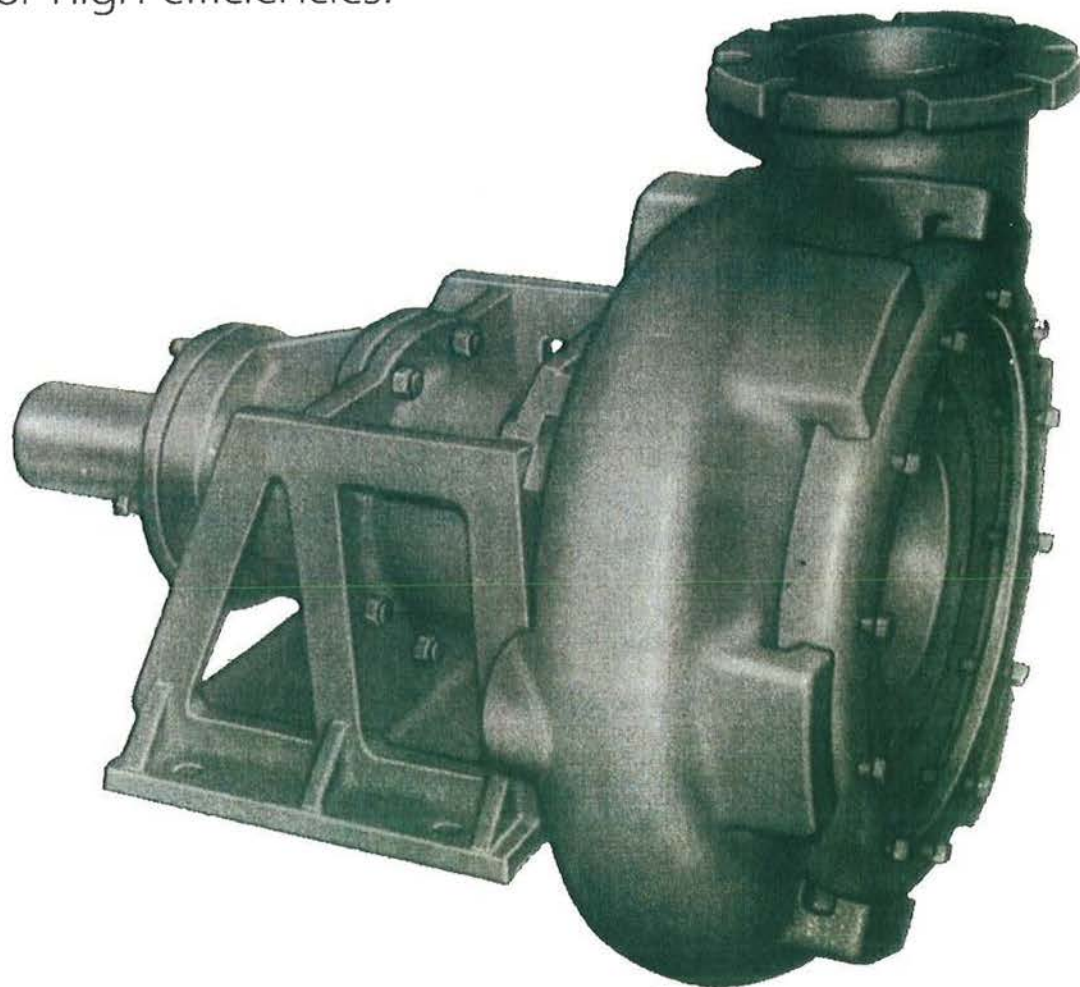

Nagle FCH Horizontal Pumps

FCH Horizontal Pumps feature compact enclosed bearing frame design with advanced large passage impeller for high efficiencies.



Endurance engineered for maximum service

High performance for slurry solids

Capable of handling slurries with solids, the Nagle FCH Horizontal Pump can tolerate a wide range of abrasive and corrosive applications. Also available in FDV-H configuration for dry pit operation. These pumps incorporate many design features developed over more than 50 years of field experience.

Endurance engineered design features

- Large impeller passages to reduce wear, allow maximum solids handling.
- Heavy wall sections for maximum service life.
- Adjustable impeller maintains design conditions.
- Bearing isolators (Inpro) used to extend bearing life.
- Heavy double row bearings for durability and extended bearing life.
- All components piloted to insure concentricity during maintenance, impeller adjustment and assembly.
- Front and back vanes for axial load control and stuffing box pressure reduction.
- Stainless steel gland is standard.
- Finite element designed shaft for minimum deflection and stress at packing.
- Computer designed impeller: high efficiency, 5 or 6 blade designs.
- Sizes 1" through 12", capacities to 8,000 USGPM.

Options

- Dry packing in box (no seal water).
- Mechanical seals.
- Dynamic seal available on selected sizes.
- Suction inducers on selected sizes.
- Priming inductor for positive priming with heavy solids.

For additional information on our complete line of finest quality industrial pumps, contact the Nagle representative in your area, or call us direct.

Specifications subject to change without notice.



Nagle Pumps, Inc.

3565 Dixie Highway
Dry Ridge, KY 41035

Phone: 859.428.5416
Sales@NaglePumps.com
www.NaglePumps.com

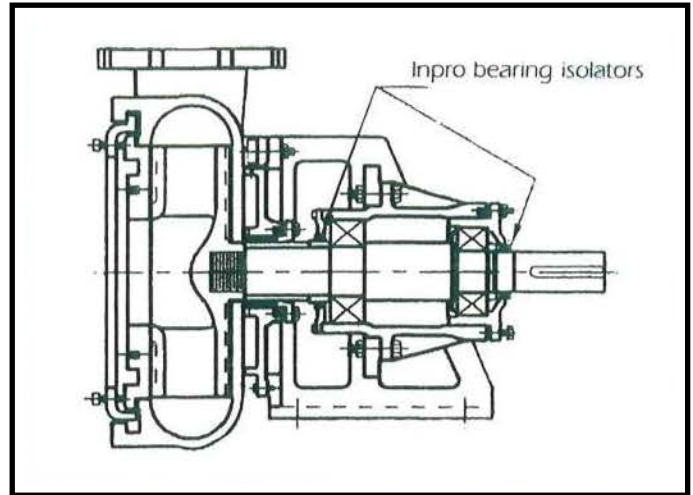

Isolators extend bearing life

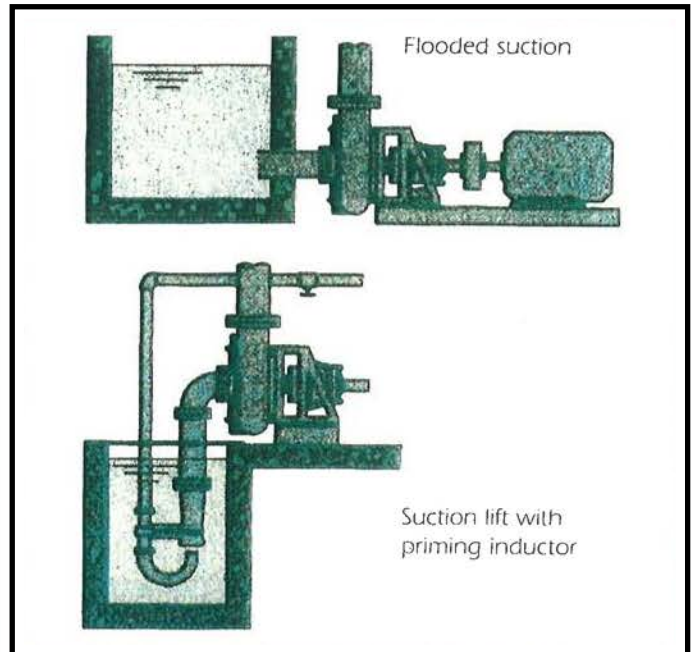

Mounting options

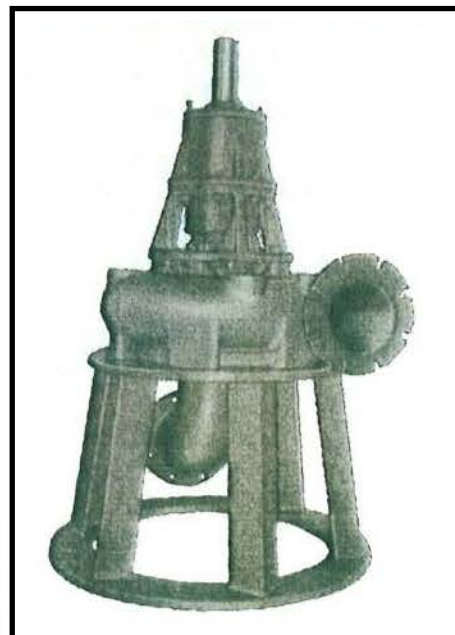

Model FDV-H
Dry Pit